



Pesticide Application Equipment & Calibration

Pesticide Application Equipment

- **Is available for the following:**
- Weed control
- Pesticides in orchards, vineyards, row crops, and field crops
- Injecting into the soil
- Animals
- Controlling aquatic pests
- Controlling pests in buildings and residences
- Many other special purposes

Liquid Application Equipment

- Consists of:
- A tank for mixing and holding the pesticide
- A pump or other device to create pressure
- Nozzles for breaking the liquid into droplets
- On some, fans, pressure regulators, filter screens, control valves, agitators, booms, hoses, and fittings to improve handling, mixing, and applications

Tanks

- A non-corrosive, non-absorptive material, such as fiberglass, stainless steel, polypropylene.
- Must have a large opening with a tight fitting cover.
- 40 gallons or larger have a sight lens

Tank Plumbing

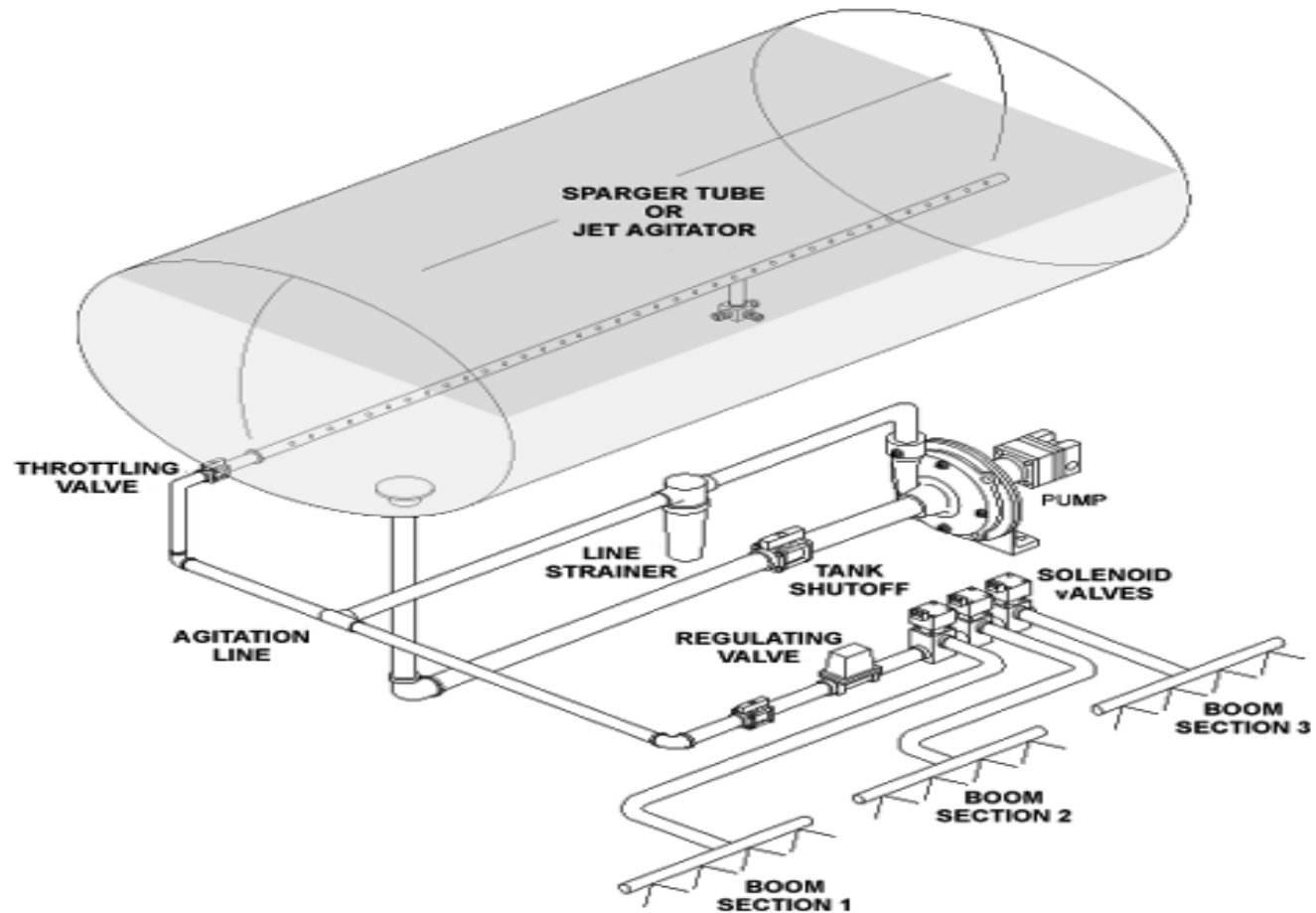

Pumps

- Output capacity: must supply enough volume for all nozzles under every use condition.
(GPM)
- Pressure: must produce the desired capacity at a pressure for the work you perform. (PSI)
- Resistance to corrosion and wear.
- Ease of repair
- Type of drive

Pump Types

■ Type	PSI	GPM	RPM	
■ Centrifugal	5-200	>200	1000-5000	
■ Diaphragm		20-700	5-40	500-
800				
■ Gear	20-100		5-65	500-2000
■ Piston	20-1000	2-60	500-800	
■ Roller	10-300		8-40	300-2000

Centrifugal Pump

- **Centrifugal pumps** are designed for use with abrasive and coarse materials. Pumping action is achieved by use of a high speed impeller that throws the material out of the pump. These pumps are used to spray high volumes, but the maximum spraying pressures are limited to 5060 pounds per square inch (psi).

Centrifugal Pump

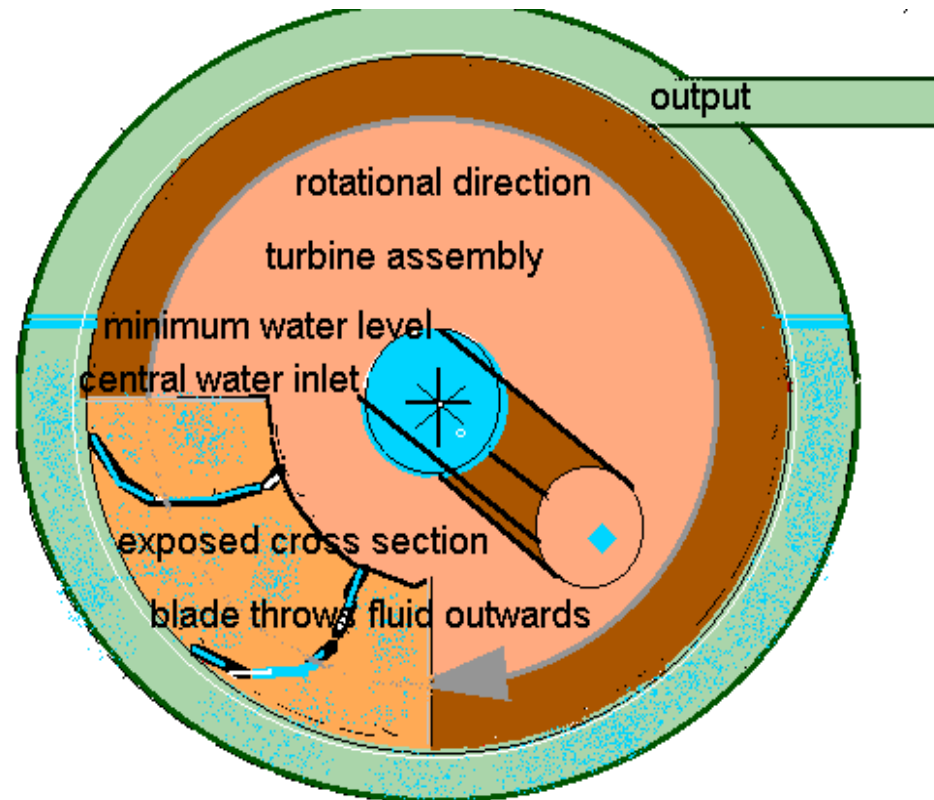

centrifugal pump action

<http://www2.murray.net.au/users/egel>

Centrifugal Pump

■ Plumbing diagram for a centrifugal pump (nonpositive displacement pump).

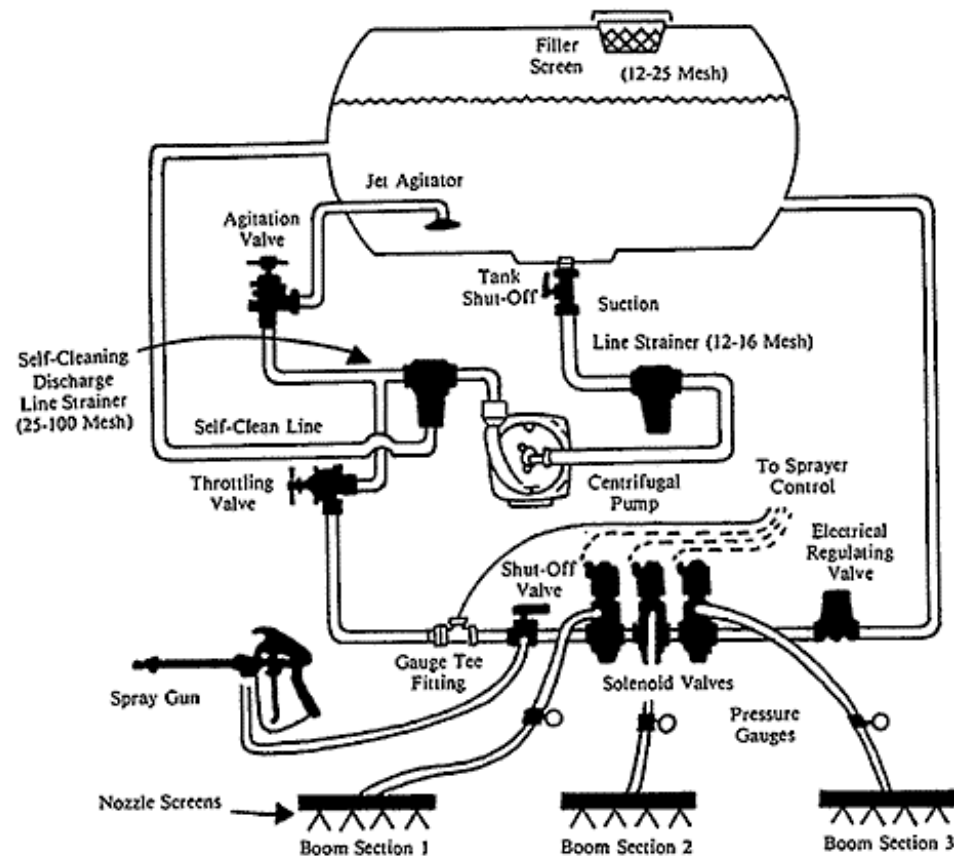

Diaphragm Pump

- **Diaphragm** pumps, although often more expensive than other pumps, have some important advantages in use and maintenance. These include: 1) a small number of moving parts; 2) a limited area of exposure of pump components to the injected chemicals; and 3) design which allows for easy adjustment of injection rate.

Diaphragm Pump

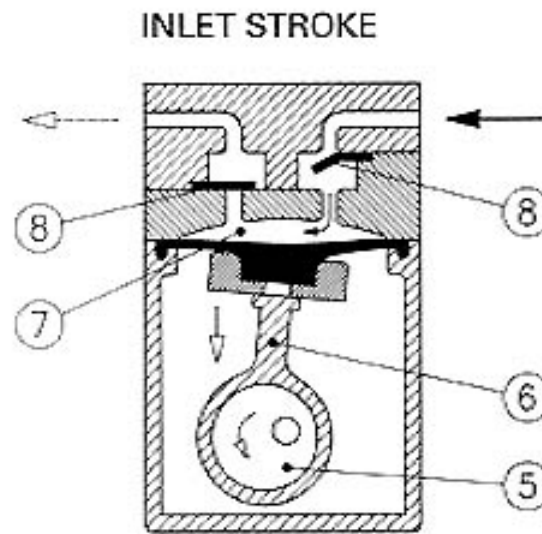
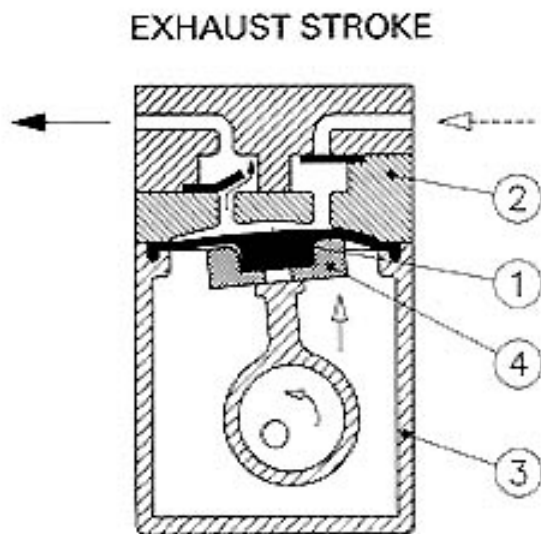

- ① Diaphragm
- ② Intermediate plate
- ③ Pump housing
- ④ Support
- ⑤ Eccentric
- ⑥ Connecting rod
- ⑦ Working chamber
- ⑧ Valve plate

Gear Pump

- **Gear pumps** are semi-positive pumps that develop uniform, moderate pressures but output volume is limited. They cannot be used with abrasive materials.

Gear Pump

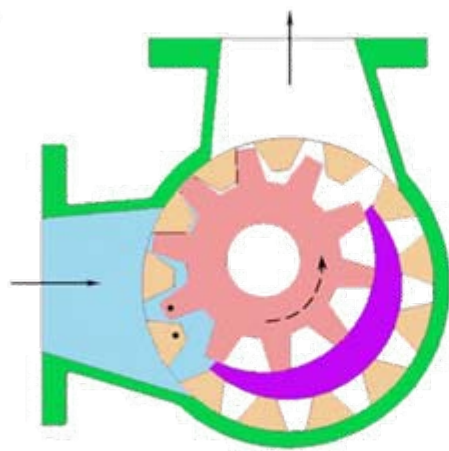

FLOW INTO

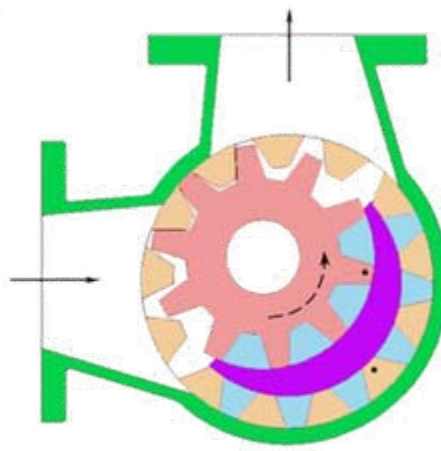

PROCESS

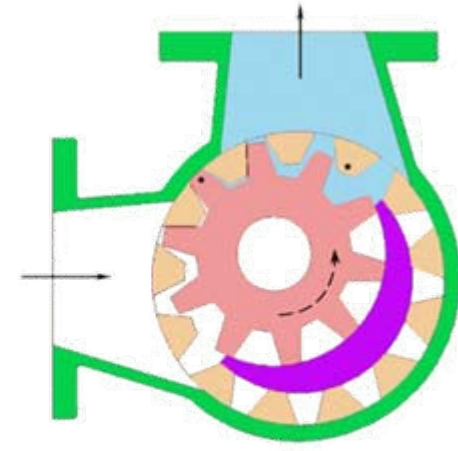

FLOW OUT

Piston Pump

- **Piston pumps** are among those most commonly used for applying agricultural chemicals. These are positive displacement pumps that can be used for both corrosive and abrasive materials. The two types of piston pumps are for different application purposes: high pressure-low volume-high speed, and low pressure-high volume-low speed applications.

Roller Pump

Plumbing diagram for a roller pump (positive displacement pump).

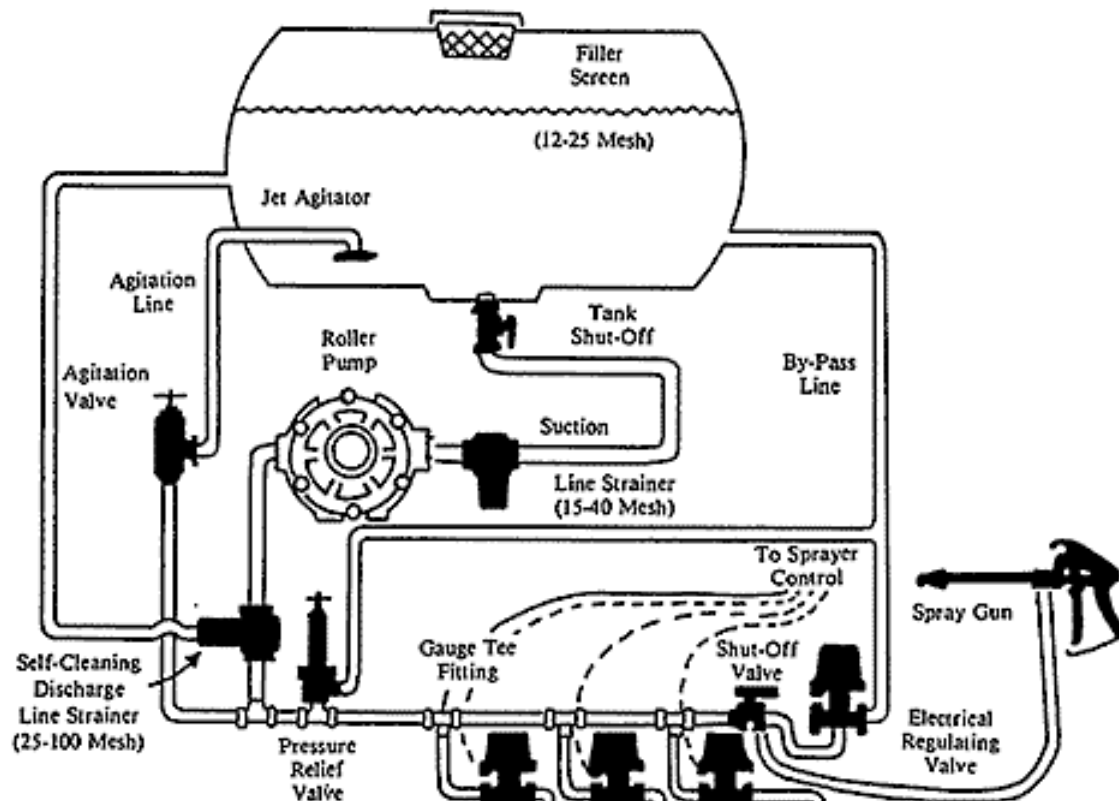

Roller Pump

- **Roller or roller impeller pumps** are also used in many agricultural spray systems. These pumps are adaptable to a wide range of pressures, volumes, and materials. They are accurate in the amount of spray material applied because they maintain constant pressure and flow.

Agitation

- Spray systems need agitation to mix chemicals initially.
- Use an agitator when using:
 - Wettable powders
 - Water-dispersible granules
 - Flowables
 - Emulsions

Types of Agitators

- Hydraulic types circulate spray back through jets located at the bottom of the spray tank. There has to be at least a foot clearance between tank wall and agitator. These types cannot breakup settled material at the bottom.
- Mechanical types are propellers or paddles mounted on a shaft near the bottom of the tank. More maintenance is required on these types.

Filters Screens and Strainers

- Protect pumps and prevent clogged nozzles. They are able to remove undissolved clumps of pesticide formulation, sand, soil, and other debris.
- Suction strainers are usually between the tank and pump.
- Pressure strainers are usually between the pump and nozzles.
- Nozzle strainers are usually at the nozzle itself.
- Filter screens can range from 10 to 200 mesh, the larger the number the finer the screen.

Nozzles

- Spray nozzles control:
 - Application rate
 - Droplet size
 - Spray pattern
- Nozzles are one of the most important parts of the sprayer, selection is critical based upon:
 - Type of material
 - Style of nozzle
 - Nozzle orifice size

Nozzle Materials

- Brass – inexpensive, and wear out quickly
- Stainless steel – more expensive, last longer
- Aluminum & Monel – resist corrosion
- Plastic – least expensive, least durable
- Tungsten carbide and ceramic – strongest but most expensive, use only under extreme high pressures.

Nozzle Types

- Flat spray – boom sprayers with overlap
- Even flat spray – uniform w/o overlap banding
- Off-center flat spray – emit to one side, use at end
- Cone – applications to foliage for good coverage
- Disk-core – air blast applications, with spinners
- Solid stream – used in hand guns band treatment
- Flood – large volumes under low pressure
- Broadcast – use for wide swath, when no boom

Nozzle Assembly

Most nozzles have four major parts: the nozzle body, the cap, the strainer (screen), and the tip or orifice plate. They also may include a separate spinner plate. Successful spraying depends on the correct selection, assembly, and maintenance of the nozzles

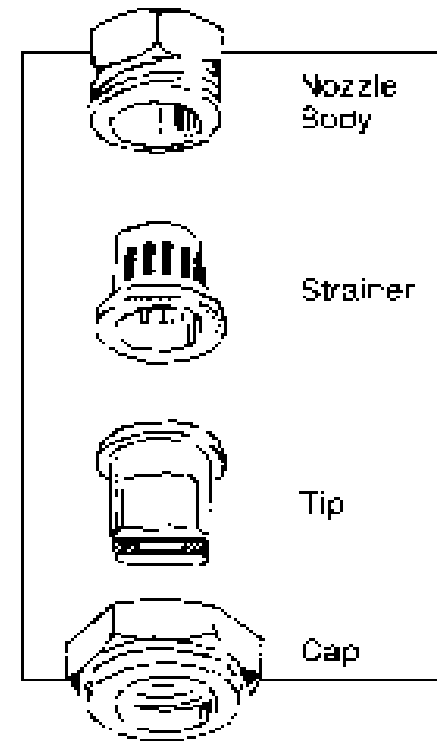

Nozzle Spray Overlap

Spray Overlap (100 Percent)

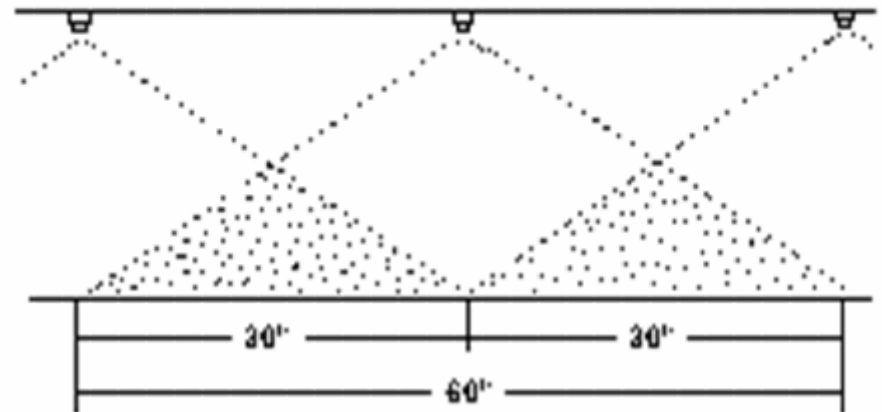

Hand-gun sprayers

- Use this equipment for:
 - Spot treatments to trees, shrubs, roadways, right-of-ways, and animals and touch-up applications.
 - **Advantages:**
 - simple to operate,
 - easy to clean and store.
- **Limitations:**
 - pressure and output rate fluctuate,
 - often provide too little agitation to keep wettable powders in suspension; must be shaken frequently.



Pressure Regulators

- A spring loaded valve that controls the pressure of the liquid going to the nozzles.

Pressure Gauge

- A monitoring device to determine the pressure at various points in a spray system.



Control Valves

- Either manual or solenoid types, both function to shut off liquid being pumped to the nozzles.



Spray Shields

- Installed on spray booms helps to confine droplets and prevent drift.

Closed-System

- Used with most dangerous chemicals, the system allow the handler to not have to come in contact with the pesticide as a open container.



Types of Application Equipment

Aerosol Cans

- a sealed container of compressed gas and pesticides. The pesticide is driven through an aerosol-producing nozzle when the valve is activated. Pressurized cans usually have a capacity of less than 1 quart and are not reusable. Larger reusable cylinders are available for some specialty agricultural uses.

Hose-End Sprayers

- This device causes a fixed rate of pesticide to mix with the water flowing through the hose to which it is attached. The mixture is expelled through a high-volume nozzle. These sprayers usually hold no more than 1 quart of concentrated pesticide, but because the concentrate mixes with the water, they may deliver 20 gallons or more of finished spray solution per fill.

Trigger Pump Sprayer

- This device causes a fixed rate of pesticide to mix with the water flowing through the hose to which it is attached. The mixture is expelled through a high-volume nozzle. These sprayers usually hold no more than 1 quart of concentrated pesticide, but because the concentrate mixes with the water, they may deliver 20 gallons or more of finished spray solution per fill.

Compressed Air Sprayers

- Usually a hand-carried sprayer that operates under pressure created by a self-contained manual pump. The air in the tank is compressed by the pump. The compressed air forces liquid pesticide through the hose and nozzle whenever the control valve is opened. A few types of these sprayers use carbon dioxide cartridges instead of a hand pump for compression. Capacity is usually 1/2 to 3 gallons.

Backpack Sprayer

- One type of backpack sprayer is a compressed air sprayer with a harness that allows it to be carried on the operator's back.
- Another type of backpack sprayer has a hand-operated hydraulic pump that forces liquid pesticide through a hose and one or more nozzles. The pump is usually activated by moving a lever. A mechanical agitator plate may be attached to the pump plunger. Some of these sprayers can generate pressures of 100 pounds per square inch (psi) or more.
- Capacity of both these types of backpack sprayers is usually 5 gallons or less.



Wick Applicator

- To apply contact or systemic herbicides with out drift or affecting non-target plants.



Powered Application Equipment

- Allows for larger volumes of pesticide to be applied because of powered compression.
- **Advantages:**
 - larger capacity than hand sprayers,
 - low- and high-pressure capability,
 - built-in hydraulic agitation,
 - small enough for limited spaces.
- **Limitations:**
 - not suitable for general field use.

Powered Backpack Sprayers

- This backpack-type sprayer has a small gasoline-powered engine. The engine drives the pump, which forces the liquid pesticide from the tank through a hose and one or more nozzles. The engine also drives air blowers, which help propel the spray droplets. This model can generate high pressure and is best suited for low-volume applications of dilute or concentrated pesticide

Controlled Droplet Applicator

- These applicators use a spinning disk (or cup) that breaks the liquid into uniformly sized droplets by centrifugal force. The droplets may be carried to the target by gravity or by an airstream created by a fan. Power to spin the disk or cup is provided by a small electric or hydraulic motor. Most CDA's do not use a pump. CDA's range in size from a small hand-held type to large tractor-mounted and trailer-mounted units.

Low-Pressure Sprayers

- These sprayers are designed to distribute dilute liquid pesticides over large areas. They deliver a low to moderate volume of spray -- usually 10 to 60 gallons per acre -- at working pressures ranging from 10 to 80 psi.
- **Advantages:**
 - medium to large tanks permit relatively large area to be covered per fill,
 - versatility.
- **Limitations:**
 - low pressure limits pesticide penetration and reach.

Boom Sprayers

- Low-pressure sprayers often are equipped with sprayer booms ranging from 10 to 60 feet in length. The most common booms are between 20 and 35 feet long and contain several nozzles. The height of the sprayer boom must be easily adjustable to meet the needs of the job. Boom supports should allow the boom to be set at any height from 12 to 72 inches above the surface being sprayed. Many nozzle arrangements are possible, and special-purpose booms are available.

Boomless Sprayers

- Low-pressure sprayers that are not equipped with booms generally have a central nozzle cluster that produces a horizontal spray pattern. The resulting swath is similar to the pattern made by a boom sprayer. These sprayers are useful in irregularly shaped areas, because they can move through narrow places and avoid trees and other obstacles. Some low-pressure sprayers are equipped with a hose and handgun nozzle for applications in small or hard-to-reach areas.

High-Pressure Sprayers

- These sprayers are used to spray through dense foliage, thick animal hair, to the tops of tall trees, and into other areas where high-pressure sprays are necessary for adequate penetration and reach. Often called "hydraulic" sprayers, they are equipped to deliver large volumes of spray -- usually 20 to 500 gallons per acre -- under pressures ranging from 150 to 400 psi or more.

High-Pressure Sprayers

■ Advantages:

- provide good penetration and coverage of plant surfaces,
- usually well-built and long-lasting if properly cared for.

■ Limitations:

- large amounts of water, power, and fuel needed,
- high pressure may produce fine droplets that drift easily.

Airblast Sprayers

- Airblast sprayers use a combination of air and liquid to deliver the pesticide to the surface being treated.
- These sprayers usually include the same components as low-pressure or high-pressure sprayers, plus a high-speed fan. Nozzles operating under low pressure deliver spray droplets directly into the high-speed airstream. The air blast shatters the drops of pesticide into fine droplets and transports them to the target. The air blast is directed to one or both sides as the sprayer moves forward, or it may be delivered through a movable nozzle.
- May cover a swath up to 90 feet wide and reach trees up to 70 feet tall.

Airblast Sprayers

■ Advantages:

- good coverage and penetration,
- mechanical agitation,
- high capacity,
- can spray high or low volumes,
- low pump pressures.

■ Limitations:

- drift hazards,
- use of concentrated pesticides may increase chance of dosage errors,
- not suitable for windy conditions,
- hard to confine discharge to limited target area,
- difficult to use in small areas,
- high power requirement and fuel use.

Ultra-low-volume (ULV) sprayers

- Use special pesticide concentrates. ULV sprayers may be hand-held or mounted on either ground equipment or aircraft.
- **Advantage:**
 - no water is needed, so less time and labor are involved.
- **Limitations:**
 - drift hazards,
 - coverage may not be thorough,
 - high concentrates present safety hazards,
 - use of concentrated pesticides may increase chance of dosage errors,
 - few pesticides are labeled for ULV.

Electrostatic Sprayers

- Give the pesticide a positive electric charge as it leaves the nozzles. Plants naturally have a negative charge, so the positively charged pesticide is attracted to the plants. The spray is directed horizontally through or above the crop (depending on the pesticide being applied).

Granular Applicators

- designed primarily for soil applications. They range from crank- operated, spinning disc backpack units which broadcast granules, to field equipment designed for broadcast, band or drill applications of granular pesticides. Granules are normally applied before or at planting and worked into the soil. Post-plant side dress applications made during cultivation through drop tubes and fertilizer shoes are another common method of granular application.

Chemigation

- The application of both water and agricultural chemicals through irrigation systems is called chemigation. As with other methods of applying agricultural chemicals, there are both benefits and risks associated with chemigation. The most significant risk is potential contamination of the water supply; therefore, to minimize risks, an irrigation system used to apply agricultural chemicals must be properly equipped and operated.

Chemigation

- Equipment required to apply chemicals through an irrigation system includes:
 - a chemical supply tank with agitator
 - an injection pump
 - a calibration tube
 - proper safety and anti-pollution devices to prevent potential contamination of the water source.

Other Types of Applicators

- Bulb Applicators
- Dusters (compressed-air, mechanical, power)
- Granule Applicators (hand, mechanical, powered)
- Livestock face and band dust bags
- Poultry dust boxes
- Dipping vats and spray/dip machines



Inspection and Maintenance

- Always check for the following:
 - Weakened Hoses
 - Leaking Fittings
 - Damage to the Tank or Coating
 - Broken Regulators and Gauges
 - Worn Nozzles
 - Worn Bearings
 - Damaged Tires
 - Other Defects

Maintaining Sprayer Equipment

- Proper maintenance of sprayer equipment is essential to its proper performance. Several steps are involved in maintaining sprayers:
- 1. Use only clean water during application and cleaning.
- 2. Keep proper screens in place.
- 3. Never use a metal object for cleaning nozzles.
- 4. Do not lock a pump solidly to a tractor.
- 5. Lubricate the pump properly and fill with antifreeze or a light oil when not in use.
- 6. Flush a new sprayer before use.
- 7. Clean sprayers thoroughly after each use.
- 8. For extended periods of storage, exposed metal parts should be coated with a light oil to prevent rusting.

Cleaning Between Different Chemicals

- After using potent herbicides, more extensive cleaning procedures are required to prevent possible crop injury.
 - a. Remove and clean all screens and nozzles with kerosene;
 - b. Pump kerosene or fuel oil through the sprayer;
 - c. Circulate a cleaning solution (1 lb detergent in 40 gal of water) through the bypass for 30 min. Flush part through the sprayer. Empty the remainder;
 - d. Fill the tank with water and ammonia (1 quart ammonia per 25 gallons of water). Pump enough to fill the hoses and nozzles, then leave for 24 hours.
 - e. Empty the sprayer and rinse with clean water.



CALIBRATION

Calibration

- Conversions to know:

$$\text{GPM} = \frac{\text{GPA} \times \text{MPH} \times W}{5940}$$

$$\text{GPA} = \frac{5940 \times \text{GPM}}{\text{MPH} \times W}$$

$$\text{MPH} = \frac{\text{Distance (feet)} \times 60}{\text{Time (Seconds)} \times 88}$$

$$1 \text{ ACRE} = 43,560 \text{ sq ft}$$

Calibration

- Calculating output: output is generally shown in volume per area.

For example: 5 gallons sprayed on 1 acre is the same as 5 GPA

Problem 1)

Jose has a sprayer with a tank capacity of 500 gallons, he sprays 10 acres and doesn't have any material left over, we also know that he sprayed the entire 10 acres accurately what is his spray volume?

$$500 \text{ gallons} / 10 \text{ acres} = 50 \text{ GPA}$$

Calibration

■ Problem 2)

Dewayne has an airblast sprayer he is going to spray 50 acres of Almonds, he fills his 500 gallon tank, and sprays one block. The rows are 20 feet wide (tree to tree), and the blocks rows are 500 feet long he goes up and back before filling up to determine his GPA he has to refill the tank with 200 gallons, what is his spray volume?

$500 \text{ ft row} \times 2 = 1000 \text{ lineal feet} \times 20 \text{ feet wide} = 20000 \text{ square feet}$

$20,000 / 43560 = .46 \text{ acres}$

$200 \text{ gallons} / .46 \text{ acres} = 435 \text{ GPA}$

Calculating dosage: Dosage is generally shown as volume to volume

1 quart of chemical per 5 gallons of water is a ratio of 1: 20

Calibration

■ Problem 3)

- Paul wants to apply 2 quarts of touchdown per acre he took Jose's spray rig which applies 50 gallons per acre. How much Touchdown will Paul put in each 500 gallon tank?

$500 \text{ gallons} / 50 \text{ GPA} = 10 \text{ acres}$

$10 \text{ acres} \times 2 \text{ quarts} = 20 \text{ quarts}$ or 5 gallons Touchdown per 500 gallon tank mix.

Therefore the ratio is 1:100

Calibration

■ Problem 4)

- If Terry wants to spray 275 acres using the above information How much Touchdown will he need?

275 acres / 2 quarts per acre = 137.5 quarts or 35 gallons of Touchdown

Calibration

■ Problem 5)

At 3 mph with 45 PSI wanting 50 GPA having 16 nozzles spaced at 20 inches apart what should the GPM be?

$$\text{GPM} = \frac{50 \text{ (GPA)} \times 3 \text{ (MPH)} \times 20 \text{ (inches)}}{5940}$$

$$\text{GPM} = .50$$

What should the ml/min be?

$$1 \text{ gal} = 3785 \text{ ml.}$$

$$.50 \text{ GPM} = 1912 \text{ ml/min}$$

Calibration

■ Problem 6)

A tractor travels 88 feet in 60 seconds what is the speed in MPH?

$$\text{MPH} = \frac{\text{Distance} \times 60}{\text{Time} \times 88} = 1$$

A sprayer travels 350 feet in 140 seconds what is the speed in MPH?

$$\text{MPH} = \frac{350 \times 60}{140 \times 88} = 1.7$$

MPH or 352 ft/min, how many acres is it spraying per minute?

$$\frac{15 \times 352}{43,560} = .12 \text{ acres/min}$$

Calibration

■ Problem 7)

The sprayer is calibrated to apply 25 GPA, you want to apply 2 pints of “Gramoxone” per acre what is the mixture ratio?

$25 \text{ GPA} \times 2 \text{ pints/acre} = 50 \text{ pints}$

ratio is 1: 50

what is the percentage?

$50/1 = 2\%$

How many gallons of Gramoxone will you add to 500 gallons of water?

$500 \text{ gal H}_2\text{O} / 25 \text{ GPA} = 20$

$20 \times 2 \text{ pints} = 40 \text{ pints or } 5 \text{ gallons}$

Calibration

■ Problem 8)

If you were to add 2% dry sulfur by weight, how much Sulfur would you add to the 500 gallon tank?

Water = 8.3 lbs./gallon

$8.3 \times 500 = 4150$ lbs/tank of water

$4150 \times 2\%$ or $.02 = 83$ lbs of sulfur

Calibration

■ Problem 9)

If you were to add 1% v/v of Induce adjuvant, how much would you add to the 500 gallon tank?

500 gallons x 1% or .01 = 5 gallons of induce per 500 gallons of tank mix.